



ARX model based fault detection and diagnosis for chillers using support vector machines



Ke Yan, Wen Shen, Timothy Mulumba, Afshin Afshari*

Department of Engineering Systems and Management, Masdar Institute of Science and Technology, PO Box 54224, Abu Dhabi, United Arab Emirates

ARTICLE INFO

Article history:

Received 10 December 2013
Received in revised form 5 March 2014
Accepted 21 May 2014
Available online 26 June 2014

Keywords:

Fault detection and diagnosis
HVAC
Linear regression
ARX model
Support vector machines
Parameter estimation

ABSTRACT

Efficient and robust fault detection and diagnosis (FDD) can potentially play an important role in developing building management systems (BMS) for high performance buildings. Our research indicates that, in comparison to traditional model-based or data-driven methods, the combination of time series modeling and machine learning techniques produces higher accuracy and lower false alarm rates in FDD for chillers. In this paper, we study a hybrid method incorporating auto-regressive model with exogenous variables (ARX) and support vector machines (SVM). A high dimensional parameter space is constructed by the ARX model and SVM sub-divides the parameter space with hyper-planes, enabling fault classification. Experimental results demonstrate the superiority of our method over conventional approaches with higher prediction accuracy and lower false alarm rates.

© 2014 Elsevier B.V. All rights reserved.

1. Introduction

Only a portion of the cost of operating air-conditioning equipment is directly imputable to the energy consumed by the plant. Lack of timely maintenance/repair can lead to premature failure of components and incur significant costs. Therefore, fault detection & diagnosis (FDD) should be an integral part of the building management system (BMS) of high performance buildings.

FDD for chillers, especially for medium to large-size chillers, can play an important, perhaps central, role in a supervisory building management scheme, improving energy efficiency and reducing maintenance costs [1,2]. In recent years, research on FDD for chiller systems has gained momentum, due to the increasing cost of chillers and the energy penalty associated with sub-par operation. This is especially true in larger heating ventilation & air-conditioning (HVAC) plants where the chiller is often the most expensive piece of equipment. FDD applied to the chiller can have a high benefit–cost ratio and is therefore an attractive area of investigation.

Chiller faults are defined as events that affect the performance of subsystems or components of chillers. These faults often do not happen abruptly but become worse gradually at a slow rate over an extended period of time [3]. In 1999, Comstock and Braun

conducted a fault survey for chillers (screw and centrifugal) by gathering information from service technicians and design engineers. The resulting data from their survey is used in the validation process of this paper [4]. According to them, the majority of faults have the potential to affect the thermodynamic states of the chiller. Such are also the faults that we consider in this work:

- Fault 1 (F1): Reduced condenser water flow,
- Fault 2 (F2): Reduced evaporator water flow,
- Fault 3 (F3): Condenser fouling,
- Fault 4 (F4): Non-condensables in refrigerant,
- Fault 5 (F5): Refrigerant leak.

We develop a robust strategy that is suitable for FDD application to chillers, where both sensor faults and chiller faults may co-exist. Auto-regressive modeling with exogeneous inputs (ARX) and support vector machine techniques (SVM) are combined to construct a new hybrid model for FDD of chillers. With validated data measured during the ASHRAE Project 1043-RP [5], the proposed chiller FDD scheme effectively and accurately identifies different types of chiller faults.

1.1. Related work

In HVAC system, chiller and air handling unit (AHU) are the most studied components when it comes to FDD. Grimmeliu et al. [6] developed an empirical fault diagnostic system for a chiller,

* Corresponding author. Tel.: +971 2 8109149; fax: +971 2 8109901.
E-mail address: aafshari@masdar.ac.ae (A. Afshari).

Nomenclature

X	training data set
N	number of data samples
v	a feature
Z_t	a time series of the dependent variable
X_t	lagged time series representations of the independent variables
c	type of class (binary)
K	number of classes (multi-class)
x	a data sample in X
m	number of features
y	the class label
Y	the set of class labels
x^*	a data sample in the training data set (normal operation)
\bar{x}	a data sample in the testing data set
ω	the ARX model
θ	parameters of the training data (faulty operation) processed by the ARX model
θ^*	parameters of the training data (normal operation) processed by the ARX model
$\bar{\theta}$	parameters of the testing data processed by the ARX model
ϱ	residuals of the training data (faulty operation) processed by linear regression model
ϱ^*	residuals of the training data (normal operation) processed by linear regression model
$\bar{\varrho}$	residuals of the testing data processed by linear regression model

combining fault detection and diagnostics in a single step. A reference linear regression was modeled with data from a normally operating chiller. Peitsman and Bakker [7] used a black box model for fault detection and compared diagnostic performance of an auto-regressive moving-average model with exogenous variables (ARX) and an artificial neural network (ANN) model. ANN models had slightly better performance than ARX models in detecting faults. Qiang et al. [8] implemented another strategy using fuzzy modeling and ANN techniques. The authors quantify the normal/faulty model residuals using fuzzy sets. Fault identification is realized using neural network. The approach is validated via ASHRAE project 1043-RP [5] chiller data. Tuip et al. [9] developed a prototype procedure for an on-line, self-learning fault detection tool on building level. By taking passive user behavior into account, the tool aims to distinguish real faults from unexpected user behavior. Jia and Reddy [10] proposed an online model based FDD method for medium to large chillers. Six process faults were identified based on five features developed from fifteen monitored variables. Armstrong et al. [11] used non-intrusive load monitoring (NILM) to detect rooftop chiller faults based on their transient electrical signature. Schein et al. [12] applied a rule-based fault detection method to AHU. Du et al. [13] used the PCA method to detect faults in air dampers and VAV terminals. Kourti [14] applied the principal component analysis (PCA) method. The PCA method consists in extracting principle components through linear combination of original input variables. The purpose is to find low-dimensional factors that properly describe the process. Wang et al. [15] applied the PCA method to the AHU system. Reddy [16] proposed a general methodology for evaluating FDD methods using steady state data and evaluated four multivariate model-based FDD methods against laboratory chiller performance data. All four methods were data-driven methods: model-free fault detection with diagnosis table, multiple linear regression model with diagnosis table, PCA

model with diagnosis table, and linear discriminate analysis. Wang et al. [17] separated the FDD for system faults and sensor faults. They used a reference regression model to validate the performance indices computed from measurements. Nassif et al. [18] proposed a self-tuning model for HVAC systems. Li and Wen [19] developed and validated an air-handling unit simulation model to produce fault free and faulty data and assess the performance of AHU automated fault detection and diagnosis methods. They then derived a data-driven FDD methodology using Principal Components Analysis (PCA) method. Zhao et al. [20] proposed a pattern recognition based chiller fault detection method using support vector data description. Magoulès et al. [21] developed a recursive deterministic perception (RDP) neural network for building energy consumption fault detection and diagnosis. Qin et al. [22] first proposed a hybrid approach to solve the FDD problem for VAV terminals.

In this paper, we study a novel hybrid approach by combining an auto-regressive moving-average model with exogenous variables (ARX) model with SVM for FDD on chiller systems. Although ARX models have been used in the past for HVAC FDD (e.g. [7,23]), we complement the approach by applying SVM to the parameter set. The SVM analysis of the parameter data set represents a significant improvement over the ARX-based FDD methods relying solely on parameter threshold checking. The measured data set is pre-processed by estimating a dynamic ARX model at each time step: for each sample, we calculate a set of parameters (i.e., a point in the parameter space) to replace the original sample for training and testing with SVM. The ARX model is first used as forecasting method to predict possible faults in FDD [7,23,24]. The parameters of a stationarized time series under normal operations remain in the range of their normal values. If some physical changes happen in the system, some or all of the model parameters will deviate from their normal values. SVM is proven to be a strong machine learning technique to capture these parameter deviations [25,26].

1.2. Contribution

We improve prediction accuracy and reduce false alarm rates compared to existing FDD approaches through combining the ARX model and SVM. In the validation section, we implement and compare four approaches:

- a pure data-driven approach which applies SVM with different kernels directly to the original data set;
- a hybrid approach which pre-processes the data set using a linear regression model and applies SVM on residuals;
- a hybrid approach which pre-processes the data set using an ARX model and applies neural network classifiers on parameters;
- a hybrid approach which pre-processes the data set using an ARX model and applies SVM on parameters.

The first two methods assume that the underlying system is static. The last two methods explicitly accounts for the dynamic nature of the time series under analysis. We use actual chiller data for normal and faulty operation corresponding to ASHRAE Project 1043-RP [5]. The results clearly indicate the superiority of the hybrid approach combining ARX model and SVM over the other alternatives.

1.3. Approach

Given a set of training data X measured at N equi-distant time instants (time step: 2 min) including both normal and faulty operational periods, each element $x \in X$ consists of M features $\{v_1, v_2, \dots, v_M\}$ and belongs to a class $y (y \in Y, Y = \{0, 1, \dots, 5\})$ where 0 indicates normal operation and a non-zero index corresponds to one of the 5 faults). We select m features from the initial set of

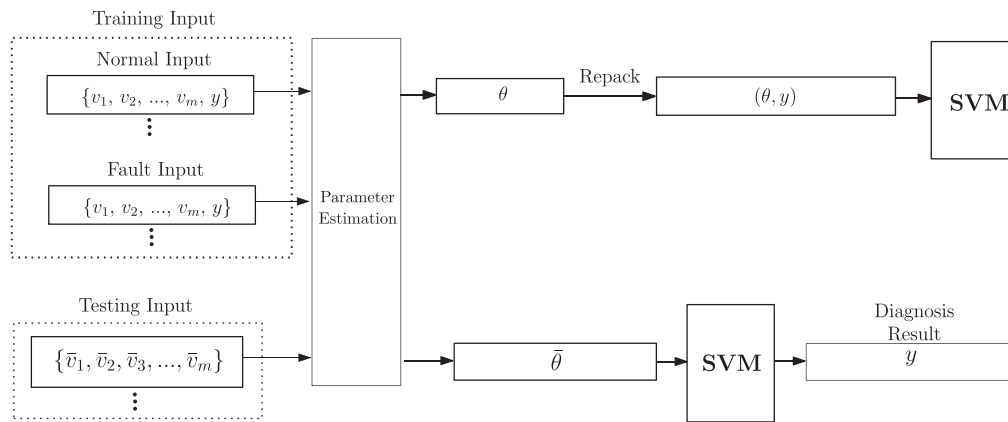

Fig. 1. The flow chart of the proposed FDD algorithm.

M features using a feature selection algorithm called *ReliefF* [27] and construct a time series ARX model. For each data sample $x \in X$, we estimate a vector of parameter θ uniquely specifying the ARX model. By gathering all θ , the original data set X is converted to a parameter set Θ , where each $x \in X$ corresponds to a $\theta \in \Theta$. The ARX model is a dynamic time series model in nature, however, we assume that the system quickly reaches its stationary state after the occurrence of each fault. Additionally, it is assumed that the transition from normal to faulty operation does not affect the basic structure of the system; only the parameters differ. This is consistent with the nature of the process. The largest time constant of the process does not exceed 10 min (5 time steps), therefore we set aside the transient effects by eliminating from the parameters set 5 samples immediately following the occurrence of a given fault. The justification is that speed of detection/diagnosis is not crucial in our application, at least not within ± 10 min. The parameter set Θ and the associated class set Y are used to train a machine learning model called support vector machine (SVM). In the testing phase, the parameters corresponding to testing samples are also calculated and subsequently fed to SVM (Fig. 1).

2. Proposed method description

2.1. Data

The chiller data were generated during ASHRAE Project RP-1043 [5]. Several common chiller faults were artificially introduced and the resulting operational data was recorded at 10-s and 2-min intervals. We use the 2-min interval data to train and test our FDD methods.

The project contains both normal and fault data for a 90-tonne (316 kW) chiller. Based on the results of chiller fault survey [5] and our understanding of the most common faults in the region, five typical faults were investigated in this study:

- Reduced condenser water flow (F1),
- Reduced evaporator water flow (F2),
- Condenser fouling (F3),
- Non-condensables in refrigerant (F4),
- Refrigerant leak (F5).

Each faulty mode was monitored in four severity levels, which are 10%, 20%, 30% and 40%, respectively. The ASHRAE report presents a series of sensitivity tests, to determine the main variables among all the variables measured. In this work, we use the reduced data set, logged every 2 min, in order to be closer to a realistic low-cost implementation. For each severity

level of each fault, we have a data file of approximately 432 samples.

2.2. Feature selection

The original data set consists of 65 monitored variables which may create heavy computational load for models and classifiers if they were all to be analyzed. In a realistic implementation, we may be short of sensors to capture such comprehensive data set or some sensors (e.g., pressure sensors) may be difficult to retrofit onto an existing plant. A feature selection technique is then crucial to select the most relevant and accessible variables.

ReliefF has been proven to be a strong and successful attribute estimator for SVM [28–30]. Therefore, we implement it hereafter to select the most significant features. For each attribute A , the ReliefF algorithm assigns a weight $W(A)$ according to its importance in influencing the output. The most heavily weighted attributes are selected as model features.

The basic idea behind ReliefF algorithm (Algorithm 1) is to exhaustively search the space and make choice of evaluation metrics. For all attributes A , the weights of A are initially set to zero (line 1). Over e iterations, where e is a user-defined parameter, a random instance R_i is selected (line 3). The algorithm then searches for one nearest neighbor of R_i , which is from the same class of R_i and another nearest neighbor of R_i , which is from a different class. The first nearest neighbor of R_i , which comes from the same class, is called the nearest hit H and the second nearest neighbor, which comes from a different class, is called the nearest miss \bar{H} (line 4). In line 6, $\text{diff}(R_i(A), H(A))$ calculates the difference between R_i and H for attribute A . The negative sign indicates difference between R_i and H is not desirable. On the contrary, $\text{diff}(R_i(A), \bar{H}(A))$ which calculates the difference between R_i and \bar{H} for attribute A is desirable. All weights of A are then updated accordingly.

Algorithm 1. Pseudo code for ReliefF algorithm

```

1: set all weights  $W(A) = 0.0$ ;
2: for  $i = 1$  to  $e$ 
3:   randomly select an instance  $R_i$ ;
4:   find nearest hit  $H$  and nearest miss  $\bar{H}$ ;
5:   for  $A = 1$  to  $a$ 
6:      $W(A) = W(A) - \frac{\text{diff}(R_i(A), H(A))}{e} + \frac{\text{diff}(R_i(A), \bar{H}(A))}{e}$ ;
7:   end for
8: end for

```

The top ten significant dependent variables selected by the ReliefF algorithm are listed in Table 1. From those, we choose only kW , $TCO.TCI$ and $TEO.TEI$ as benchmark variables for ARX modeling. As suggested in the original report of ASHRAE project 1043-RP,

Table 1
Ten most important features/variables selected from the original data set.

Feature	Description	Weight
<i>kW</i>	Instantaneous input power	0.09402
<i>TCO_TCI</i>	Condenser water temperature difference	0.03724
<i>TEO_TEI</i>	Evaporator water temperature difference	0.03545
<i>PRE</i>	Evaporator pressure	0.01854
<i>PRC</i>	Condensor pressure	0.01699
<i>TRC_sub</i>	Subcooling	0.01512
<i>kW/ton</i>	Chiller efficiency	0.01455
<i>TEA</i>	Evaporator approach temperature	0.01378
<i>TCA</i>	Condenser approach temperature	0.00859
<i>Tsh_dis</i>	Discharge superheat	0.00026

the most convenient and informative independent variables are *TCI*, *TEO* and *EvapTons*, respectively condenser input water temperature, evaporator output water temperature and tons of cooling delivered by the evaporator coil (a calculated variable).

2.3. ARX model

ARX models are a special type of the more general ARIMAX models. ARIMAX models are, in theory, the most general class of dynamic models for forecasting a non-stationary time series which can be stationarized (remove drift in mean and variance) by transformations such as differencing. Contrary to regression models, the ARX representation fully characterizes the dynamic nature of the process. Advantageously, the model parameters can be estimated recursively which is ideal for online implementation (e.g. [23]). One possible limitation of the model is that it requires a time interval for the estimation algorithm to recognize the impact of a fault on the parameters. However, immediate detection of abnormal operations is not usually required in HVAC plants. A reasonable delay (of the order of the largest time constant in the system) is acceptable. Figs. 2 and 3 show auto-correlation (ACF) and partial auto-correlation functions (PACF) of the chiller consumption. The damping toward zero evident in the auto-correlations is consistent with stationary auto-regressive components with real roots. The

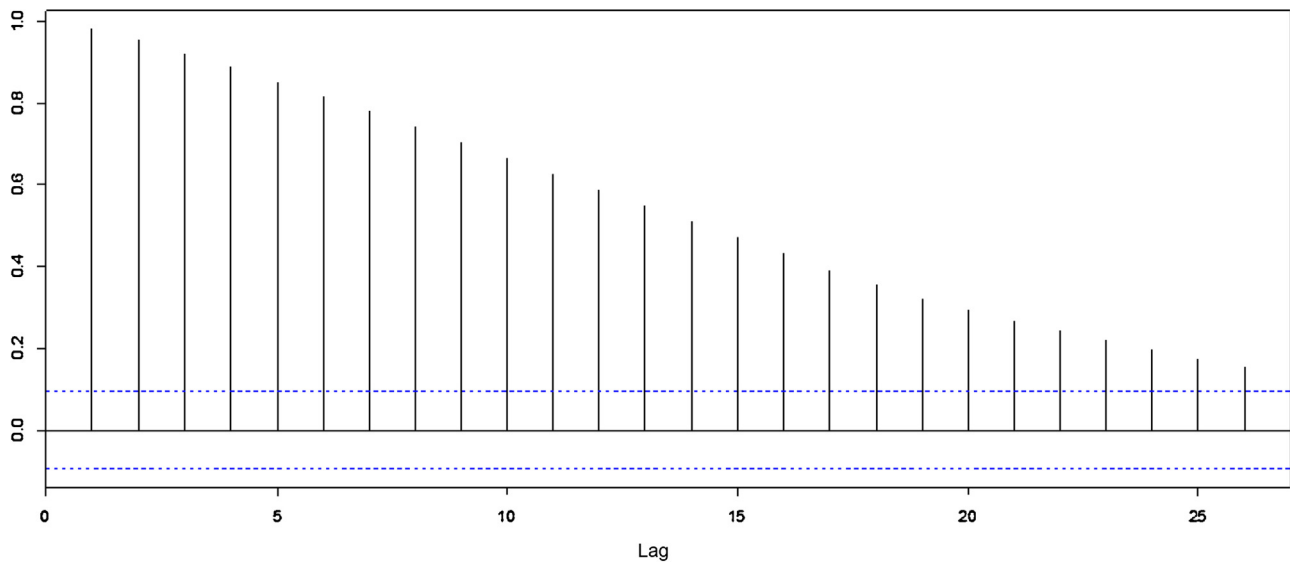

Fig. 2. ACF chiller consumption (kW).

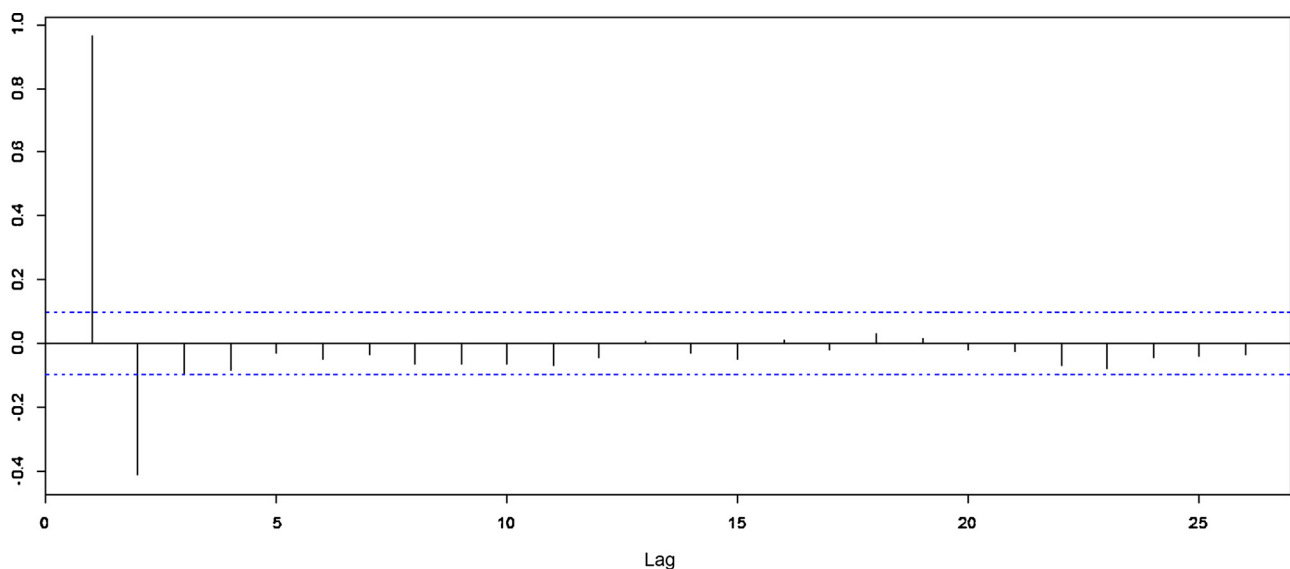

Fig. 3. PACF chiller consumption (kW).

Table 2
Candidate lags.

Explained/exogenous	TEO	TCI	EvapTons
kW	0, 1, 2	0	0, 1
TCO_TCI	0, 1, 2	0, 1, 2	0, 1, 2
TEO_TEI	0	0	0

sample partial auto-correlations are evidently strongly positive at 1 and strongly negative at lag 2, but appear to drop off there-after, suggesting an auto-regression of order 2. Thus an AR(2) model is explored as an initial model for this data.

Pre-whitening. Pre-whitening is applied to the dependent variables (kW, TCO_TCI and TEO_TEI) to determine the suitable lags for each parameter. In practice, although the system may be non-stationary, the data may be transformed to white noise by replacement with the residuals from a fitted auto-regressive integrated moving-average (ARIMA) model. For a quick preliminary analysis, approximate pre-whitening can be done easily by first differentiating the data (if needed) and then fitting an approximate AR model with the order determined by minimizing the Akaike Information Criterion (AIC) [31]. The pre-whitened data are then fitted to a model of the form below,

$$Z_t = \beta_0 + \beta_1 X_{t-i} + u_t, \tag{1}$$

where Z_t is a time series of the dependent variable, and X_t includes all suitably lagged time series representations of the independent variables (appropriately lagged values of TEO, TCI and EvapTons in this case) and u_t follows an ARIMA (p,d,q) model.

Lag selection. The model defined by Eq. (1) is known as the transfer-function model. The specification of which lags of the independent variable enter into the model is often done by inspecting the sample cross-correlation function based on the pre-whitened data. When the model appears to require a fair number of lags of the independent variable, the regression coefficients may be parsimoniously specified via an ARMA specification.

The result of this pre-whitening procedure is shown in Table 2 with respective candidate lags.

In Table 2, the maximum lag for all independent variables TEO, TCI and EvapTons is 2. The general ARX model can therefore be expressed as:

$$y = \theta_1 + \theta_2 y_{t-1} + a_t + \theta_3 TEO_t + \theta_4 TEO_{t-1} + \theta_5 TEO_{t-2} + \theta_6 TCI_t + \theta_7 TCI_{t-1} + \theta_8 TCI_{t-2} + \theta_9 EvapTons_t + \theta_{10} EvapTons_{t-1} + \theta_{11} EvapTons_{t-2},$$

where y represents kW, TCO_TCI or TEO_TEI. Each of the three dependent variables generates a set of 11 parameters at each time step. Therefore, since we have selected to model 3 dependent variables, each data sample is converted to a set of 33 parameters.

Model validation. The ARX models produce a better fit with more statistically significant coefficients than the linear regression equivalents. This can be seen by comparing the coefficient of determination (R^2) and AIC values (Table 3). Additionally, tests on the residuals from these models show that they do not violate any of the Gauss–Markov assumptions. We have validated the model using out-of-sample data, i.e., data not used to estimate the

Table 3
 R^2 and AIC values comparison for using ARX model or linear regression equivalents.

Model	R^2		AIC	
	Linear regression	ARX	Linear regression	ARX
kW	0.9600	0.9850	2072.499	1626.373
TCO_TCI	0.9937	0.9989	-198.544	-902.102
TEO_TEI	0.9999	0.9999	1866.426	1866.426

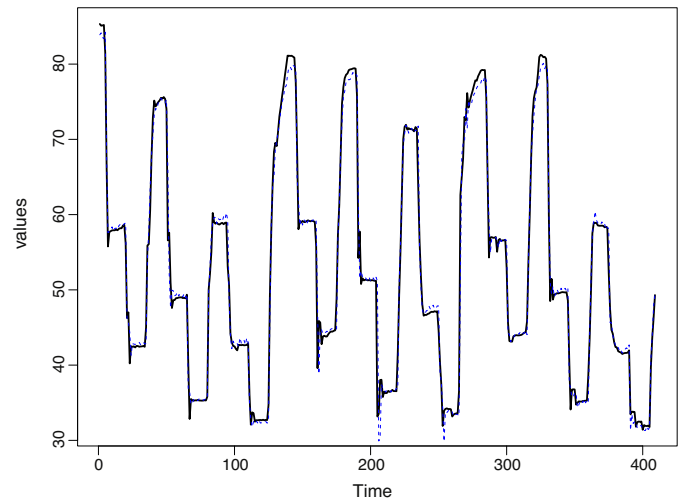

Fig. 4. Out-of-sample fit.

parameters but corresponding to similar operating conditions. The out-of-sample prediction, depicted in Fig. 4, indicates that the ARX model's prediction performance is excellent with a Root-Mean-Square Deviation (RMSE) of 1.98 (about 2.5% of the peak).

2.4. Support vector machine

In machine learning, the support vector machine is a supervised learning model that categorizes data and recognizes patterns. For a given a set of training data with known categories, an SVM machine is a model that assigns to each data sample a point in a high dimensional space. In the next step, the approach classifies the data by sub-dividing the high dimensional space using hyper-planes. Ideally, the hyper-planes separate the training samples as widely as possible to unambiguously distinguish new test sample categories.

The original SVM algorithm usually deals with two classes. An optimized hyper-plane separates the training data set into two subsets by *support vectors* [32]. In general, some key settings are required before the SVM starts: (1) choosing kernel functions, such as polynomial, sigmoid, Gaussian radial basis function (RBF), etc., and to map inputs onto a high dimensional space; (2) selecting SVM formulation, such as C-support vector classification (C-SVC), ν -support vector classification (ν -SVC) and distribution estimation (one-class SVM). These SVM formulations determine the classification algorithm used to divide the sample space.

Suppose the training input consists of n samples, given a data sample (x, c) , where $x \in X$ and $c \in \{+1, -1\}$, the classification function is expressed in the dual space:

$$f(x) = \sum_{i=1}^N w_i \sigma_i(x) + b. \tag{2}$$

In this equation, σ_i is the kernel function predefined in the SVM model, and w_i and b are the adjustable parameters of the classification function. We choose the Gaussian radial basis function (RBF) as the kernel function because of its superior performance in this application. The class z is decided by the sign of $f(x)$, or alternatively,

$$c = \frac{f(x)}{\|f(x)\|}. \tag{3}$$

The basic SVM classifier only deal with two classes. For multi-class identification using SVM, we adopt the 'one-against-all' algorithm which constructs one two-class SVM classifier between each pair of classes.

One-against-all multi-class SVM. Consider an K -class classification problem, where we have N training samples: $\{x_1, y_1\}, \dots, \{x_N, y_N\}$. Here $x_i \in R^m$ is a m -dimensional feature vector and $y_i \in \{1, 2, \dots, K\}$ is the corresponding class label.

One-against-all approach constructs K binary SVM classifiers, each of which separates one class from all the rest. The i th SVM is trained with all the training examples of the i th class with positive labels, and all the others with negative labels. Mathematically the i th SVM solves the following problem that yields the i th decision function $f_i(x) = w_i^T \phi(x) + b_i$, minimizing:

$$L(w, \varepsilon_j^i) = \frac{1}{2} \|w_i\|^2 + C \sum_{j=1}^N \varepsilon_j^i, \quad (4)$$

subject to $\bar{y}_j (w_i^T \varepsilon(x_j)) \geq 1 - \varepsilon_j^i$, $\varepsilon_j^i \geq 0$, where $\bar{y}_j = 1$ if $y_j = i$ and $\bar{y}_j = -1$ otherwise.

At the classification phase, a sample x is classified as belonging to class:

$$i^{\text{th}} = \operatorname{argmax}_{i=1, \dots, K} f_i(x) = \operatorname{argmax}_{i=1, \dots, K} (w_i^T \varepsilon(x) + b_i). \quad (5)$$

2.5. An overview of proposed hybrid method

A hybrid approach combining ARX model and SVM is desirable to improve the accuracy of the FDD analysis. In the proposed hybrid approach, we pre-process the data using ARX models to remove auto- and cross-correlations between variables. Then, we use parameters instead of the original data to do the fault detection and diagnosis in SVM. The proposed method includes seven separate steps:

- (1) The original data set is divided into two parts. The first 2/3 is used as historical data or training input. The rest 1/3 of the data are treated as testing samples. The training data samples are categorized according to their fault types (normal, F1, F2, . . . , F5).
- (2) Using ReliefF to select most important features, dependent and independent variables are chosen, respectively. It is noted that each dependent variable can be expressed as an equation of some or all independent variables.
- (3) The ARX model is trained by selected features. Each dependent variable (kW , TCO_TCI or TEO_TEI) generates a set of 11 parameters at each time step. Therefore, each data sample is converted to a set of 33 parameters. The whole original data set is transformed into a set of ARX model parameters.
- (4) Two separate SVM are trained. The binary SVM library deals with the fault detection and the multi-class SVM library diagnoses faults.
- (5) The testing sample is pre-processed by the trained ARX model and transformed into parameter set.
- (6) The binary SVM library is applied to the testing parameter set to detect faults. The positive result indicating normal operation data is put aside waiting for final conclusion.
- (7) If the result in step (6) is negative, the testing parameter set is input into the multi-class SVM library. A deterministic fault type will be assigned to that sample.

Finally, the prediction accuracy and false alarm rates can be concluded. The overall flowchart is depicted in Fig. 5.

3. Results

In this section, the proposed hybrid method for FDD on chillers is validated with the data from ASHRAE Project 1043-RP. We divide the reduced data set (2 min interval) into two subsets with a ratio

Table 4

The fault detection accuracy and false alarm rates with different levels and different types of faults resulting from the direct application of SVM on chiller data.

Accuracy (%)	All faults	F1	F2	F3	F4	F5	False alarm (%)
All levels	72.09	67.03	96.93	87.02	98.66	77.67	20.22
Level 1	69.47	62.37	88.55	76.48	94.66	55.73	12.98
Level 2	76.21	71.14	99.24	85.25	100.00	64.89	11.32
Level 3	81.75	74.28	100.00	89.77	96.38	92.37	12.73
Level 4	85.19	88.20	100.00	89.82	100.00	97.71	13.44

of 3:1. The first subset is the training data set, where all data samples are assigned to fault labels. A fault label can be *Normal*, *Fault 1*, *Fault 2*, *Fault 3*, *Fault 4* or *Fault 5*, which corresponds to normal data, reduced condenser water flow, reduced evaporator water flow, condenser fouling, non-condensables in refrigerant and refrigerant leak, respectively. The second subset (2 times smaller) is the testing data set, where all data samples have unknown fault label. The fault labels of the testing data set are only revealed after the fault diagnosis in order to calculate the classification accuracy and false alarm rates.

To evaluate the performance of the proposed hybrid method, we implement following FDD approaches and compare their results:

- **Approach 1.** First, we apply SVM directly to the chiller data from ASHRAE Project 1043-RP.
- **Approach 2.** Second, we construct a static regression model similar to the one suggested by the authors of the report of ASHRAE Project 1043-RP. The difference between the simulation results and the actual data, i.e. the residuals of the regression model, are used for training and testing in SVM.
- **Approach 3.** Third, we construct the ARX model and apply multilayer perceptron neural network classifiers to the parameter set.
- **Approach 4.** Last, we construct the ARX model and apply SVM to the parameter set.

Although the ARX model uses only the first three dependent variables from Table 1, all 10 variables are used in Approaches 1 and 2. Therefore, the proposed hybrid model is severely handicapped in the comparison. Nonetheless, it manages to outperform other approaches as detailed below. To facilitate comparison, we separate the steps of fault detection and fault diagnosis. Both the prediction accuracy and false alarm rates are reported.

3.1. Direct application of SVM on chiller data

In this approach, we first train a binary SVM algorithm using the training data and then perform the fault detection using the established model. The detailed results are shown in Table 4. The prediction of level 1 faults is less accurate than the others and the overall, because the data samples of level 1 faults are quite similar to normal operation. The SVM model failed to effectively distinguish the differences between them. The false alarm rates are very high exceeding 10% in all cases.

Table 5

Results of fault diagnosis for direct application of SVM to chiller data.

Accuracy (%)	All faults	F1	F2	F3	F4	F5
All levels	83.59	96.07	96.36	77.58	99.27	91.12
Level 1	74.50	85.19	86.26	74.50	98.63	82.44
Level 2	85.50	99.24	99.39	76.69	99.39	86.41
Level 3	89.11	99.54	99.54	82.36	99.37	96.63
Level 4	89.77	99.54	99.54	84.12	99.54	98.17

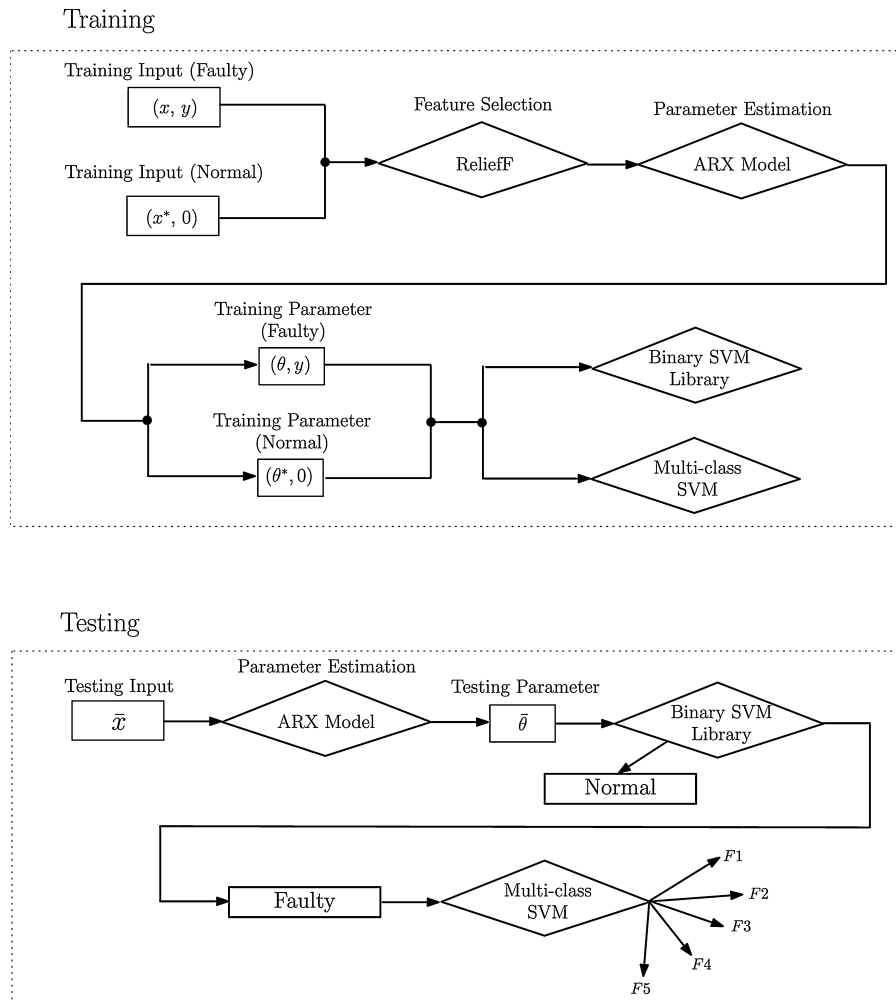

Fig. 5. Flow chart of hybrid approach for FDD.

The process of fault diagnosis is similar to that of fault detection except that we use a multi-class SVM classifier to do the classification. In our work, we use the ‘one against all’ algorithm based on SVM. The results are shown in Table 5.

3.2. Application of SVM on regression model residuals

The second procedure makes use of the regression model:

$$f(TEO, TCI, EvapTons) = a_0 + a_1 \cdot TEO + a_2 \cdot TCI + a_3 \cdot EvapTons + a_4 \cdot TEO \cdot EvapTons + a_5 \cdot TCI \cdot EvapTons + a_6 \cdot EvapTons^2, \quad (6)$$

which, according to the ASHRAE report of project 1043-RP, is the most effective regression model with the least number of inputs. The implementation overview is depicted in Fig. 6.

First, we construct the regression model with normal operational data. Both the training and testing data are processed by the constructed regression model and converted to residuals. The residuals are then input into SVM for training and testing.

The process of fault detection is divided into three steps: first, the Normal data is employed to create a regression model; second, the residuals are calculated (for both training data and testing data) using the parameters obtained in the previous step; third, a binary SVM classifier is built to classify and produce the final results. A multi-class SVM is then used for diagnosis. Table 6 shows the results in details.

Table 6

The accuracy and false alarm rates of fault detection with different fault types and levels after application of SVM on the regression model residuals.

Accuracy (%)	All faults	F1	F2	F3	F4	F5	False alarm (%)
All levels	82.58	78.04	99.81	92.84	100.00	89.23	7.38
Level 1	72.39	68.46	99.24	81.02	100.00	80.19	6.23
Level 2	77.35	74.71	100.00	89.11	100.00	84.22	3.44
Level 3	88.96	81.30	100.00	94.33	100.00	91.44	4.60
Level 4	92.67	88.20	100.00	89.82	100.00	97.71	5.80

The prediction accuracy for level 4 faults is higher than 90% in this approach, which is much better than previously. The false alarm rates for all levels are now below 8%, which, again, is a significant improvement over the previous case (Table 7).

In the fault diagnosis step too, this approach outperforms the previous approach in predicting all levels of faults.

Table 7

Results of fault diagnosis combining SVM and regression model.

Accuracy (%)	All faults	F1	F2	F3	F4	F5
All levels	87.81	97.31	97.89	82.97	99.16	93.74
Level 1	75.42	90.38	92.67	79.08	98.47	84.89
Level 2	88.55	99.54	99.39	86.11	99.24	93.13
Level 3	95.86	99.54	99.54	88.80	99.54	98.01
Level 4	95.57	99.24	99.54	88.86	99.39	98.93

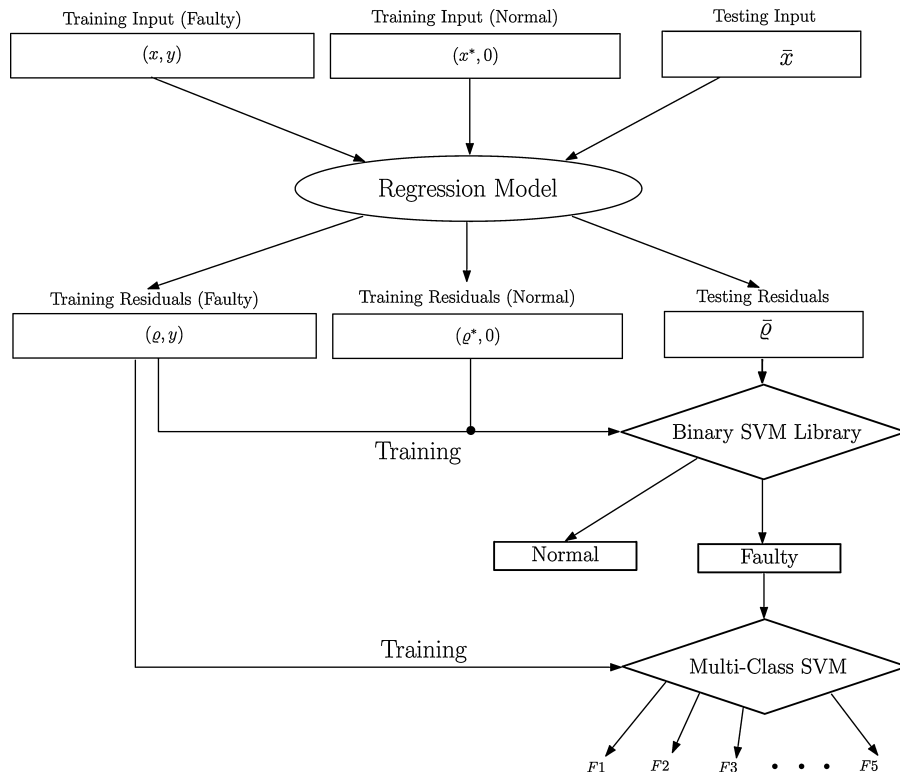

Fig. 6. Flow chart of the residual-based SVM approach.

Table 8
Results of fault detection combining multilayer perceptron network and ARX model

Accuracy (%)	All faults	F1	F2	F3	F4	F5	False alarm (%)
All levels	86.34	83.88	89.22	81.85	91.89	93.43	1.83
Level 1	82.33	79.22	80.09	77.34	88.72	89.48	3.58
Level 2	84.67	81.48	85.06	80.63	90.11	91.87	2.14
Level 3	90.26	92.27	93.88	84.87	93.07	95.72	0.90
Level 4	94.44	93.45	99.82	89.76	95.07	97.93	0.05

Table 10
Results of fault detection combining SVM and ARX model

Accuracy (%)	All faults	F1	F2	F3	F4	F5	False alarm (%)
All levels	90.12	87.22	92.87	96.01	93.14	85.81	0.11
Level 1	79.63	74.76	81.13	81.39	74.19	79.33	0.49
Level 2	89.41	88.23	97.18	88.48	90.76	88.21	0.18
Level 3	96.32	98.65	93.57	98.73	95.24	91.71	0.00
Level 4	98.27	98.49	96.89	98.90	97.60	96.19	0.00

3.3. Application of neural network to ARX model parameters

The third procedure constructs the ARX model and inputs parameters into neural network classifiers to do the fault detection and diagnosis. We compare the result of two neural networks: the radial basis function network and multilayer perceptron network. The better result of the two, which is obtained from the multilayer perceptron network, is shown in Tables 8 and 9.

Table 11
Results of fault diagnosis combining SVM and ARX model.

Accuracy (%)	All faults	F1	F2	F3	F4	F5
All levels	90.31	96.64	94.90	94.23	98.92	93.07
Level 1	88.42	96.71	92.02	92.68	95.96	84.10
Level 2	94.55	95.93	95.94	95.46	99.61	96.93
Level 3	95.32	96.98	95.93	95.79	99.72	96.17
Level 4	96.71	98.75	95.98	95.79	99.72	97.94

3.4. Application of SVM to ARX model parameters

By applying SVM on the parameters generated by the ARX model, we achieve the best overall result among all four procedures. Results are shown in Table 10 and 11. Both prediction accuracy and false alarm rates are improved significantly compared to the previous three approaches.

Table 9
Results of fault diagnosis combining multilayer perceptron network and ARX model.

Accuracy (%)	All faults	F1	F2	F3	F4	F5
All levels	89.68	96.12	97.51	80.39	97.58	80.11
Level 1	82.34	95.33	93.86	77.80	95.96	76.34
Level 2	84.87	96.02	98.11	79.02	96.31	78.22
Level 3	92.85	98.87	99.83	88.27	98.98	86.19
Level 4	96.31	99.75	99.98	92.65	99.76	94.26

4. Conclusion

The primary contribution of this paper is that a robust FDD strategy is proposed and developed to detect and diagnose chiller faults, based on a real world data set. In order to evaluate the applicability of the strategy, we implement and compare our approach with existing FDD approaches. Results show an improvement in terms of both accuracy and false alarm rates. The ARX models produce a better fit with more statistically significant coefficients than the linear regression equivalents. It is much easier for SVM to differentiate the parameter changes when a fault happens. Therefore, it is not a surprise that our solution produces better results.

In addition, only six variables (*kW*, *TCO.TCI*, *TEO.TEI*, *TCI*, *TEO* and *EvapTons*) are used in the proposed hybrid method, which is far fewer than existing approaches. The feature selection algorithm is only executed once during the training period (possibly

in controlled environment). Thereafter the FDD algorithm can be deployed on similar chiller plants where in only the required variables are measured. The use of reduced number of variable saves the cost of additional sensor installation. Moreover, only standard quality sensors are required for our approach since the time interval between each measurement is fixed at 2 min (instead of 10 s).

Applicable algorithms for implementing the strategy are formulated. After training for generic chiller types, these algorithms can be integrated in advanced building management systems to accurately detect and diagnose the 5 faults commonly observed in chiller systems.

Future work will extend the application of the hybrid method to AHUs. We are also finalizing a Kalman filter based estimation, which is suitable for on-line parameter identification.

Acknowledgements

This research was supported by the Executive Affairs Authority (EAA) of Abu Dhabi, United Arab Emirates as part of the project *Predictive Maintenance: Fault Detection and Diagnosis of AC Equipment*. The authors would also like to thank Mr. Michael Vaughn and Ms. Donna Daniel of ASHRAE for their assistance in providing the chiller data of the ASHRAE Project RP-1043.

References

- [1] M. Piette, S. Kinney, P. Haves, Analysis of an information monitoring and diagnostic system to improve building operations, *Energy and Buildings* 33 (2001) 783–791.
- [2] Y. Song, Y. Akashi, J. Yee, A development of easy-to-use tool for fault detection and diagnosis in building air-conditioning systems., *Energy and Buildings* 40 (2) (2008) 71–82.
- [3] J. Gertler, *Fault Detection and Diagnosis in Engineering Systems*, Marcel Dekker, New York, 1998.
- [4] M. Comstock, B. Chen, J. Braun, Literature review for application of fault detection and diagnostic methods to vapor compression cooling equipment, in: Ray W. Herrick Laboratory Report HL 99-19, 1999.
- [5] M.C. Comstock, J.E. Braun, Experimental data from fault detection and diagnostic studies on a centrifugal chiller, in: Ray W. Herrick Laboratories, HL 99-18, Purdue University, West Lafayette, IN, 1999.
- [6] H. Grimmelius, J. Woud, G. Been, On-line failure diagnosis for compression refrigerant plants, *International Journal of Refrigeration* 18 (1) (1995) 31–41.
- [7] H. Peitsman, V. Bakker, Application of black-box models to HVAC systems for fault detection., *ASHRAE Transactions* 102 (1) (1996) 628–640.
- [8] Q. Zhou, S. Wang, F. Xiao, A novel strategy for the fault detection and diagnosis of centrifugal chiller systems, *HVAC&R Research* 15 (1) (2009) 57–75.
- [9] B.G.C.C. Tuip, M.A. Houten, M. Trcka, J.L.M. Hensen, Occupancy based fault detection on building level – a feasibility study, in: *Proceedings of the 10th International Conference Enhanced Building Operations ICEBO*, Kuwait, 2010, p. 6.
- [10] Y. Jia, T. Reddy, Characteristic physical parameter approach to modeling chillers suitable for fault detection, diagnosis, and evaluation, *Journal of Solar Energy Engineering, Transactions of the ASME* 125 (3) (2003) 258–265, *Emerging Trends in Building Design, Diagnostics, and Operations*.
- [11] P.R. Armstrong, C.R. Laughman, S.B. Leeb, L.K. Norford, Detection of rooftop cooling unit faults based on electrical measurements, *International Journal of HVAC&R Research* 12 (1) (2006) 151–175.
- [12] J. Schein, S.T. Bushby, N.S. Castro, J.M. House, A rule-based fault detection method for air handling units, *Energy and Buildings* 38 (12) (2006) 1485–1492.
- [13] Z. Du, X. Jin, X. Yang, A robot fault diagnostic tool for flow rate sensors in air dampers and VAV terminals, *Energy and Buildings* 41 (3) (2009) 279–286.
- [14] T. Kourti, Application of latent variable methods to process control and multivariate statistical process control in industry, *Journal of Adaptive Control and Signal Processing* 19 (4) (2004) 213–246.
- [15] S. Wang, F. Xiao, AHU sensor fault diagnosis using principal component analysis method, *Energy and Buildings* 36 (2) (2004) 147–160.
- [16] T. Reddy, Application of a generic evaluation methodology to assess four different chiller FDD methods (rp-1275), *HVAC&R Research* 13 (5) (2007) 711–729.
- [17] S. Wang, Q. Zhou, F. Xiao, A system-level fault detection and diagnosis strategy for HVAC systems involving sensor faults, *Energy and Buildings* 42 (4) (2010) 477–490.
- [18] N. Nassif, S. Moujaes, M. Zaheeruddin, Self-tuning dynamic models for HVAC system components, *Energy and Buildings* 40 (2008) 1709–1720.
- [19] S. Li, J. Wen, A model-based fault detection and diagnostic methodology for secondary HVAC systems (PhD thesis), Drexel University, 2009.
- [20] Y. Zhao, S. Wang, F. Xiao, Pattern recognition-based chillers fault detection method using support vector data description (SVDD), *Applied Energy* 112 (2013) 1041–1048.
- [21] F. Magoulès, H.-x. Zhao, D. Elizondo, Development of an RDP neural network for building energy consumption fault detection diagnosis, *Energy and Buildings* 62 (2013) 133–138.
- [22] J. Qin, S. Wang, A fault detection and diagnosis strategy of VAV air-conditioning systems for improved energy and control performances, *Energy and Buildings* 37 (10) (2005) 1035–1048.
- [23] W.Y. Lee, C. Park, G.E. Kelly, Fault detection in an air handling unit using residual and recursive parameter identification method, *ASHRAE Transactions* 102 (1) (1996).
- [24] G. Mustafaraja, J. Chen, G. Lowry, Development of room temperature and relative humidity linear parametric models for an open office using BMS data, *Energy and Buildings* (2010) 348–356.
- [25] H. Han, B. Gua, J. Kang, Z. Li, Study on a hybrid SVM model for chiller FDD applications, *Applied Thermal Engineering* 31 (4) (2010) 582–592.
- [26] J. Liang, R. Du, Model-based fault detection and diagnosis of HVAC systems using support vector machine method, *International Journal of Refrigeration* (2007) 1104–1114.
- [27] M. Robnik-Šikonja, I. Kononenko, Theoretical and empirical analysis of ReliefF and RReliefF, *Machine Learning* 53 (1–2) (2003) 23–69.
- [28] Z. Liu, D. Ma, Z. Feng, A feature selection algorithm based on svm average distance, in: *Measuring Technology and Mechatronics Automation (ICMTMA)*, 2010, pp. 90–93.
- [29] M.H. Nguyen, F. de la Torre, Optimal feature selection for support vector machines, *Pattern Recognition* (2010) 584–591.
- [30] B. Qi, C. Zhao, E. Youn, C. Nansen, Use of weighting algorithms to improve traditional support vector machine based classifications of reflectance data, *Optics Express* 19 (27) (2011) 26816–26826.
- [31] Y. Sakamoto, M. Ishiguro, G. Kitagawa, *Akaike Information Criterion Statistics*, D. Reidel, Dordrecht, The Netherlands, 1986.
- [32] N. Cristianini, J. Shawe-Taylor, *An Introduction to Support Vector Machines and Other Kernel-based Learning Methods*, Cambridge University Press, 2000.